

REPORT

AOS GROUP*

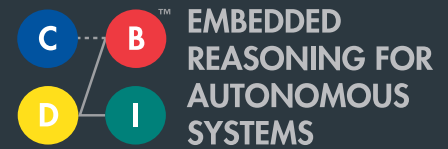

CoJACK™

A Moderated BDI
Cognitive Architecture
for Realistic Virtual Actors

AOS

Introduction

In the past decade, the computer games industry has developed truly impressive photorealistic 3D virtual environments. These are in widespread use in homes all around the world and have also been adapted to military applications. In the military context, photorealistic environments (e.g. VBS2™) are used for training and mission rehearsal, whereas tactics development, course of action analysis and hardware acquisition studies tend to be performed on more traditional virtual environments. Typically, whether for games or military applications, simulated human entities are an essential part of the scenario. However, in contrast to hardware such as aircraft, tanks and weapons systems, even highly-trained humans can vary significantly in their response to a given situation. Although the inherent variability of humans has been widely recognized, virtual environments have tended to neglect this phenomenon because it is very difficult to model the depth and breadth of human behavior.

CoJACK™ is a novel cognitive architecture, based on JACK®, AOS's BDI (Beliefs/Desires/Intentions) autonomous agent platform. CoJACK predicts how human behavior varies as a function of the changes to the architecture's parameters. It supports the definition of moderators that modulate these parameters and thereby predicts *in a principled way* how behavior varies as a result of physiological and affective factors (e.g. fear).

CoJACK is unique in its synthesis of an easy-to-use BDI representation with a cognitive architecture. In contrast to cognitive architectures that divide tasks into very small steps (cf. ACT-R [1]), CoJACK combines JACK's high-level plan representation with sub-symbolic computations that influence processing without obscuring that high-level viewpoint. Earlier cognitive architectures have various strengths and weaknesses, but none were designed to offer an intuitive, high-level representation.

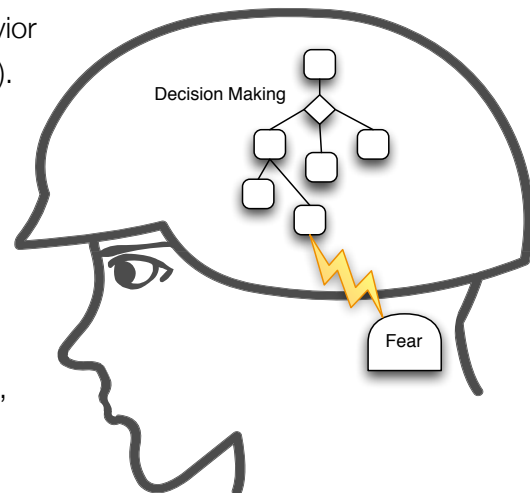

Decision Making

CoJACK is intended to provide improved behavioral realism in synthetic human agents for CGF and computer gaming applications. In all but the most trivial cases, an agent will have a number of alternative actions available to deal with the current situation. The mental process of selecting an action to perform is termed **decision making**. This process can be either rational or irrational, and when the pressure is on, can be a knee-jerk reaction to the situation, with little or no thought as to the overall consequences of the action.

Many factors can contribute to a decision, including:

1. Situation Awareness – the appreciation of those aspects of the current situation that are relevant to the question at hand.
2. Predictive Capability – the ability of the agent to foresee the consequences of actions and the likely actions/reactions of other entities that are part of the scenario.
3. Response Repertoire – the known action sequences for dealing with the current situation (skill set).
4. Personal Preference – preferred methods of dealing with the current situation, often based on experience of previous successes and failures.
5. Cognitive Effectiveness – the current state of the underlying cognitive architecture, affecting capabilities such as ability to recall facts, hold intermediate results in working memory, and stay focused on the problem.
6. Affective State – the emotional factors that can influence a decision, for example, a high-level of fear can predispose a person to make an irrational decision.

These factors contribute to individual differences in decision making and, ideally, should be reflected in a synthetic human agent. Typically, synthetic human entities are implemented in relatively inflexible scripting languages. In contrast, JACK® offers a high-level plan language that provides intelligent and flexible responses to the situation. Using JACK, one can represent the first four of the above decision making factors. However, a JACK agent will coolly execute its plans without error and as fast as the hardware platform allows. As such, it fails to model the underlying properties of and variability in human cognition; a JACK agent will not forget what it knows and can perform computational feats that are well outside the capabilities of humans. This leads to unrealistic performance because even highly-trained humans vary in their response to a given situation. This, then, was the motivation for adding a cognitive architecture to JACK. CoJACK alters the performance of a JACK agent so that it more closely resembles how a human would perform the task at hand.

Knowledge Representation

One of the key discriminators that sets JACK apart from other modeling languages is its ease of use. JACK employs a diagrammatic representation that uses natural language to describe the goals, contexts, reasoning steps, and actions of agents. These descriptions can then be fleshed-out by programmers to produce executable models whose computational structure mirrors the SME's (Subject Matter Expert's) specifications. CoJACK preserves this ease of use by using the same knowledge representation as JACK. Indeed, CoJACK models look the same as JACK models. However, the behavior of a CoJACK agent will be quite different to a JACK agent. This is because CoJACK adds a sub-symbolic layer to JACK that affects memory retrieval and decision making.

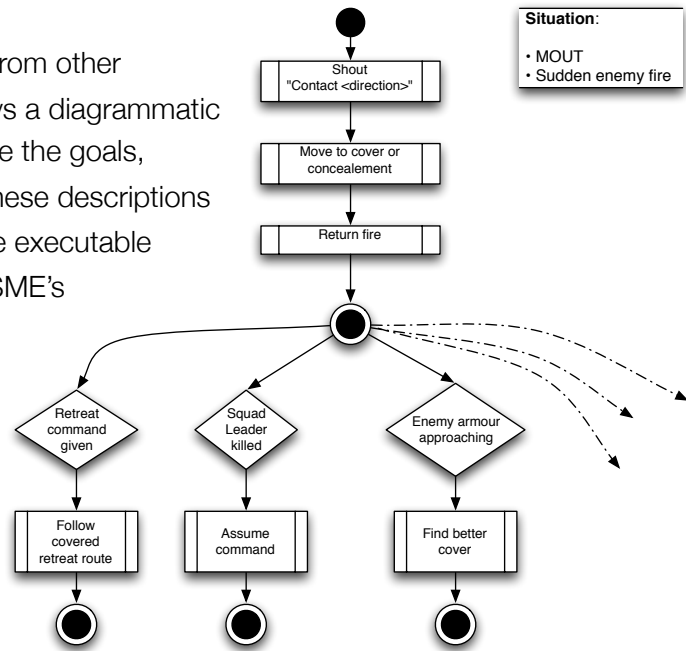

Procedural Knowledge

CoJACK uses a graphical **plan** representation to represent the agent's reasoning capability (procedural knowledge). Shown in the inset above, a graphical plan defines the context in which it is applicable and the various steps that must be followed for it to deal with the situation. Plans are triggered in response to events the agent perceives in its environment, as well as internal events the agent generates itself. These internal events can be viewed as goals that the agents adopts. For example, if under heavy fire, an agent might generate an internal event to find cover. This goal would remain active until the agent succeeds or gives up. If the agent has a repertoire of plans that can be used to achieve this goal, it will try each in turn until it has found cover.

Declarative Knowledge

In addition to its procedural knowledge ("knowing how to do something"), CoJACK agents have declarative knowledge ("knowing about"). In the "Sudden enemy fire" diagram above, knowing that the squad leader has been killed is an example of declarative knowledge. Declarative knowledge is stored in **beliefs** within the agent.

Underlying Architecture

CoJACK simulates the *structural properties* of the human cognitive system, that is, the information processing mechanisms that are fixed across tasks. It is generally accepted that humans share a common cognitive architecture – CoJACK embodies these commonalities and, in part, expresses the individual variation as differences in the values of the agent’s internal (cognitive) parameters.

For those unfamiliar with the concept of a cognitive architecture, the following analogy should help. Consider the inset diagram (right) showing a ball bearing that is released from the top of a ramp. The behavior of interest is the time taken to reach the bottom. The length of the ramp and the maximum lean angle (90°) is fixed. These are *structural properties* of the system and are analogous to the invariant properties of human cognition. The angle of lean can vary within the 90° range and the surface can be covered with different coatings (e.g. glass vs. deep pile carpet). These are *parameters* of the system, and are analogous to the internal cognitive parameters of the agent. By varying these parameters, we obtain different behavior (the ball bearing takes differing amounts of time to reach the bottom). Taken together, these factors can be used to *predict* the behavior of the ball bearing.

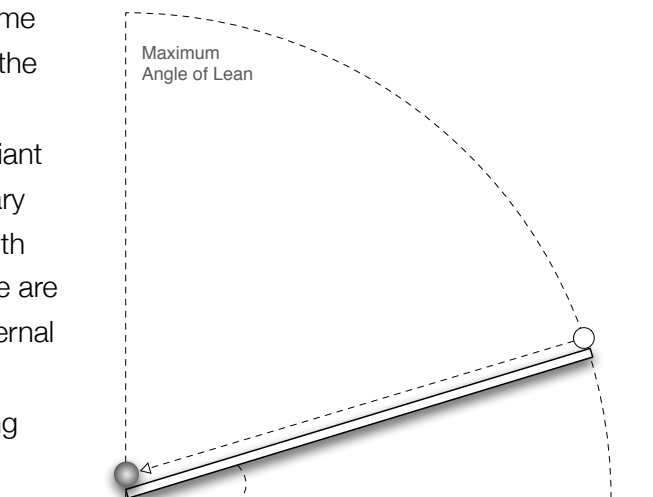

Similarly, CoJACK has invariant properties, for example memory is stored in **chunks**, chunks have an **activation level**, and an activation level can be propagated between associated chunks. As with the ball bearing example, CoJACK has parameters that can vary and lead to individual differences in behavior. Parameters can delay the agent’s reasoning steps and accelerate/decelerate memory access. Parameters can also affect which memory elements (chunks) are retrieved; this includes effects such as failure to retrieve a matching chunk, retrieval of a chunk that only partially matches, and retrieval of an alternative matching chunk (i.e. one that normally would not have been chosen first). A similar mechanism affects agent’s recall of what it is working on. Thus, the agent can forget what it was doing. Cognitive parameters can be *moderated* at runtime, leading to further variation in behavior. For example, a caffeine moderator could be added that decreases the time taken to perform reasoning steps, leading to shorter response times.

Physiology and Emotion

Physical and emotional factors can have a significant effect on behavior. For example, a drug as mundane as caffeine has been shown to reduce reaction time and increase the ability to focus, allowing performance on a vigilance task to remain virtually sustained at its original level, instead of decreasing over the span of an hour [2]. Emotions, such as fear, affect decision making and can result in irrational choices. Though irrational, these behavioral tendencies have been honed over millions of years of evolution and are so deeply entrenched even extensive training will be ignored when the emotional drive is strong enough. Consequently, these factors must be taken into account if we are to build realistic models of human behavior.

CoJACK is the first cognitive architecture to explicitly incorporate an ability to model the effects of emotion and physiology on cognition. Emotional/physical factors are modeled using **moderators**: time-based functions applied to cognitive parameters. An agent's moderators are initialized at simulation start up and can incorporate a history of prior

moderator updates, for example, expressing the fact that the agent is fatigued after a five hour march. Moderators can also have internal reservoirs and decay functions that determine how the reservoir level varies over time (e.g. to model the rate at which caffeine is excreted). Composite moderators can be created that represent the interaction between one or more moderators (e.g. the interaction between fear and resolve). The inputs to a moderator can be (i) events from the simulation environment, (ii) internal events (e.g. thoughts that trigger fear), and (iii) outputs from other moderators.

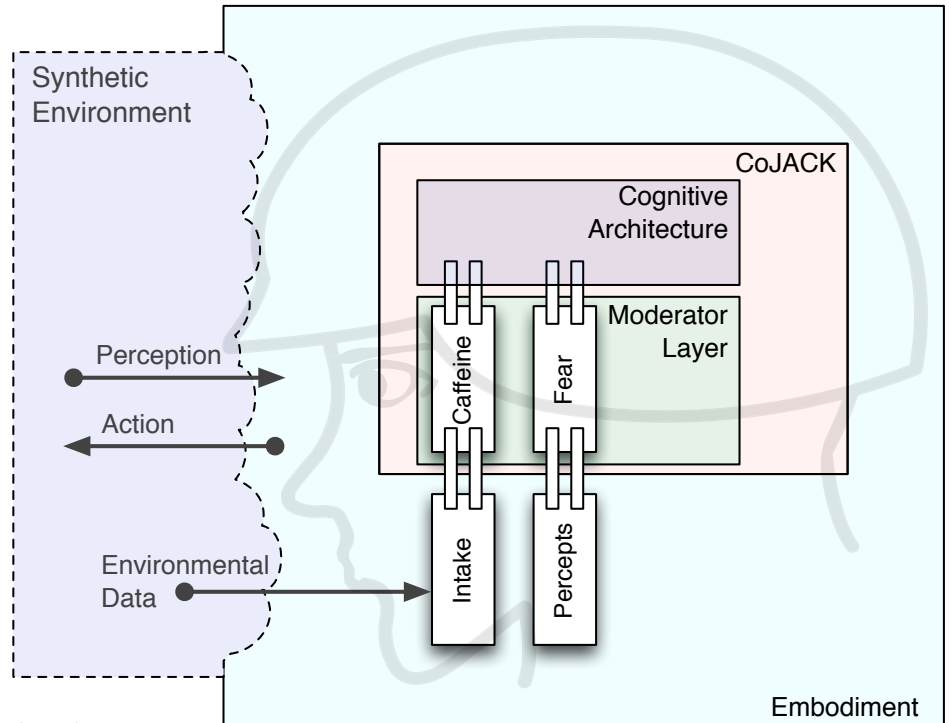

Conclusion

CoJACK is a novel BDI cognitive architecture that uses psychological principles to predict how humans will behave in a given situation. Realistic behavior variation is automatically generated as a result of the properties of the underlying architecture. The inclusion of moderators allows the creation of models that reflect how emotion and physical factors affect human decision making and behavior.

This has all been achieved without sacrificing ease of use. CoJACK offers an intuitive representation of decision making that is both underpinned by a principled cognitive architecture and capable of being moderated by physiological and emotional factors. Moreover, CoJACK achieves this without compromising JACK's high-level, intuitive tactics representation.

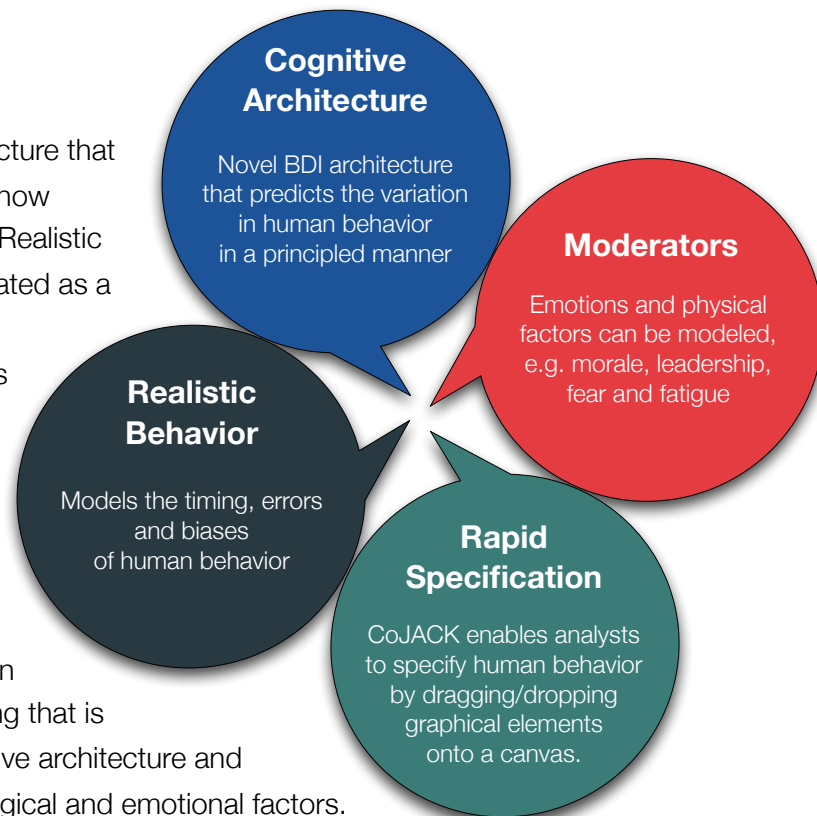

Further Information

To find out more about CoJACK, send an email to cojack@aosgrp.com

References

- [1] Anderson, J.R. (2007) *How can the human mind exist in the physical universe?*, Oxford University Press, New York, NY.
- [2] Boff, K.R. & Lincoln, J. E., (1988) *Engineering data compendium (User's guide)*, Harry G. Armstrong Aerospace Medical Research Laboratory, Wright-Patterson Air Force Base, OH.